

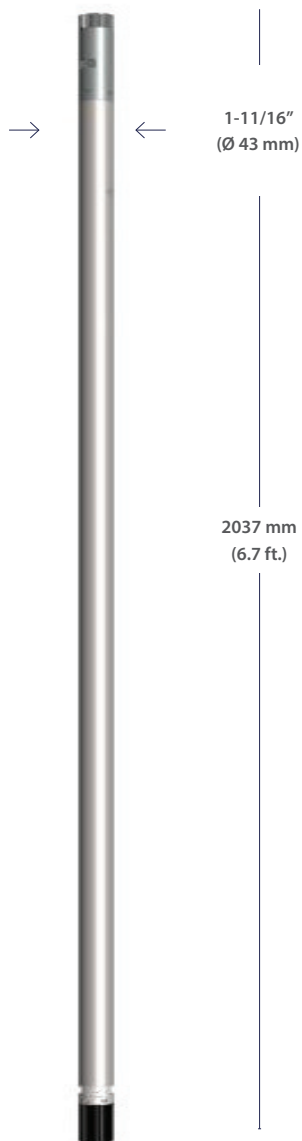

# DEFORMATION & ECCENTRICITY TOOL (DEC)

GOWell's Deformation-and-Eccentricity Tool (DEC) is a 1-11/16 in O.D tool when run inside tubing has the unique ability to inspect Casing Deformation, Tubing Eccentricity within the casing and a minimum distance between tubing and casing. The DEC tool uses a dual array of patented electromagnetic measurements to accurately map the surrounding pipe geometry. The tool employs a unique high SNR compressed-and-focused magnetic field and an array of magnetic sensors to measure the magnetic flux density distributions azimuthally around the tool which corresponds to variations in the spacing between tubing and casing. Data processing generates accurate tubular geometry and a 3D colour-enhanced image.



When run with GOWell's PegasusStar platform, the DEC is fully combinable with Multi-Finger calipers (MFC) and Magnetic Thickness Detector (MTD). The combination provides a comprehensive evaluation of the overall well barrier integrity, providing internal tubular diameter, accurate multi-pipe strings thickness information and tubular geometry (Deformation and Eccentricity). Significant casing deformation can often indicate potentially damaged cement behind the casing and the loss of formation integrity (e.g. depletion compaction or sand collapse).

## FEATURES

- 1-11/16" (42.9mm) O.D. slim tool
- Combinable with all Pegasus Series Tools
- Enhanced processing within the ViewWell™ Well Integrity Platform
- Real-time processing within Warrior 8 for wellsite evaluation

## APPLICATIONS

- Quantify Casing Deformation behind the tubing completion
- Monitor casing deformation over time
- Locate centralized pipes in proposed abandonment interval during P & A operations
- Increase MTD / ePDT thickness accuracy
- Locate fiber-optics cable clamps/control lines
- Orient multi-string tubing completion



# DEFORMATION & ECCENTRICITY TOOL (DEC)

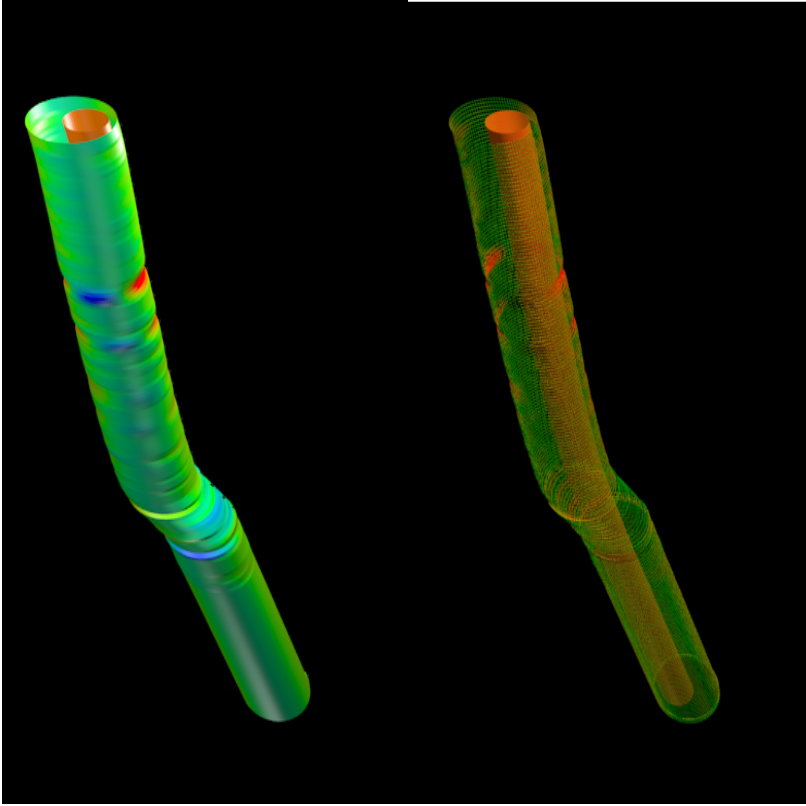

## DESCRIPTION

The DEC tool has two sets of azimuthal magnetic sensor matrix; one tubing sensor matrix and one casing sensor matrix, which deliver high accuracy measurements to image the flux density changes. DEC has a built-in orientation measurement based on gyro and accelerometers that are used to align the deformation and eccentricity images answer products, as well as the tubing thickness image. The tool measurement specifications is 2% of eccentricity ratio and 5% of deformation ratio accuracy in the range of casing OD up to 13-3/8”.

DEC 3D IMAGE

DEC 43C-A	
P/N 100901186	
GENERAL SPECS	
Maximum Diameter	43mm (1-11/16in)
Temperature Range	-20 to 175°C (-4 to 350°F)
Maximum Hydrostatic Pressure	138MPa (20kpsi)
Overall Length	2037 mm (80.2 in)
Weight	30 lbs
H2S Resistant	Yes
Recommended Logging Speed	1.5 to 9.1 m/min (5 to 30 ft/min)
Eccentricity Ratio Accuracy	2%
Deformation Ratio Accuracy	5%
Azimuthal Resolution	±7.5°
NON-MAGNETIC TUBING MEASUREMENT	
Casing Measurement Range	100 to 406 mm (4 to 16in)
STANDARD TUBING MEASUREMENT	
Tubing Measurement Range	63 to 177 mm (2.5 to 7in)
Casing Measurement Range	127 to 330 mm (5 to 13in)